

Connection Instructions #1

Differential Line Driver

Encoder signals from 5 VDC to 24 VDC (must specify the voltage when ordering)

This is the preferred type of encoder output as it has the best noise immunity. Connect each encoder signal to its like optical isolator input (A to A, A/ to A/, etc).

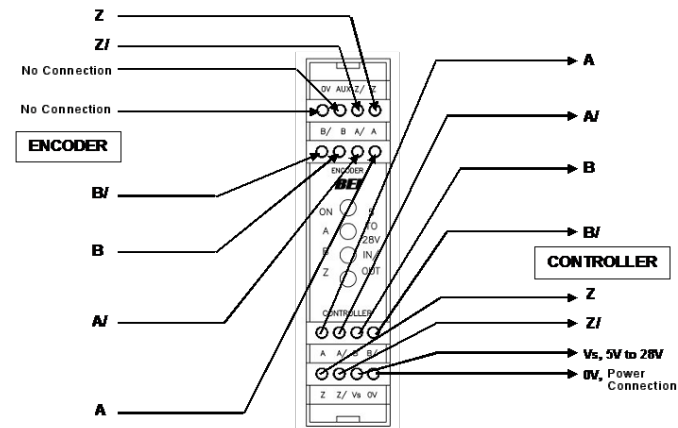
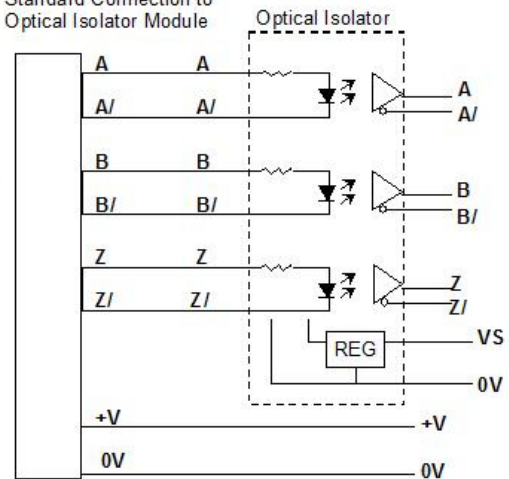

Figure 1
Standard Connection to
Optical Isolator Module



Encoder Differential Line Driver Output

Connection Instructions #2

Single Ended Line Driver

Encoder signals from 5 VDC to 24 VDC (must specify the voltage when ordering)

This is the preferred type of encoder output as it has the best noise immunity. Connect each encoder signal to its like optical isolator input (A to A, A/ to A/, etc).

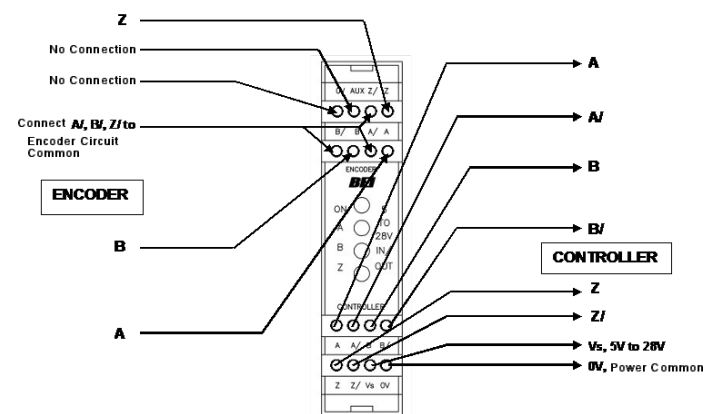
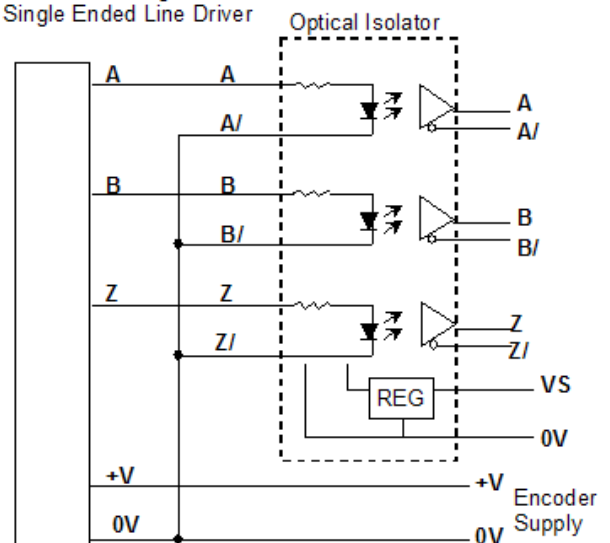

Figure 2
Connection Diagram
Single Ended Line Driver



Connection Instructions #3

Open Collector with or without Internal Pull-up Resistors

Encoder NPN (sinking) outputs. Connect encoder output A to optical isolator module input A/, B to B/ and Z to Z/. Connect the A, B, and Z inputs of the optical isolator to the auxiliary output terminal on the optical isolator module for 5V module and to higher voltage when specified by module model and part number. This connection results in a logic inversion within the optical isolator module. To compensate for the logic reversal, swap A for A/, B for B/, and Z for Z/ at the optical isolator outputs.

